

KG7TC Series Smartlite[®]

Two Stage, Fixed Speed ECM, Condensing Upflow/Horizontal Gas Furnaces

Induced Draft - 95.1 AFUE
Input 60,000 - 120,000 Btuh

The high efficiency upflow gas furnace may be installed free standing in a utility room, basement, or enclosed in an alcove or closet. Upflow/Horizontal units come ready for upflow or horizontal application. The extended flush jacket provides a pleasing "appliance appearance." Design certified by CSA for application in Canada and the United States.



This furnace series is approved and certified by the SCAQM and the SJVAPC Districts in the state of California under each Districts' Mitigation Fee Plan for shipment into and sales in both districts.

For California installations in SCAQMD only: This furnace does not meet the SCAQMD Rule 1111 NOx emission limit (14 ng/J), and thus is subject to a mitigation fee of up to \$450. This furnace is not eligible for the Clean Air Furnace Rebate Program: www.CleanAirFurnaceRebate.com.

FEATURES and BENEFITS

- **Multi-speed direct drive blower:** Energy-efficient brushless DC (ECM) motor provides 16 speeds designed to give a wide range of cooling capacities.
- **100% fired and tested:** All units and each component are tested on the manufacturing line.
- **Best packaging in the industry:** Unique corner post design assures product will arrive to the homeowner dent free.
- **30 second blower delay:** At start-up assures a warm duct temperature at furnace start-up. Adjustable blower off settings (60, 90, 120 and 180 seconds).
- **30 second post purge:** Increases life of heat exchanger.
- **Hot surface igniter:** Innovative application of an appliance type igniter with a 20 year history of reliability. Utilizes proven Smartlite[®] technology.
- **Color coded wire harness:** Designed to fit the components, all with quick-connect fittings for ease of service and replacement.
- **Flexible category IV venting system:** May be vertically or horizontally vented using either a one-pipe or two-pipe system for maximum flexibility in installation.
- **High Static Blowers:** All models equipped with high static blowers.
- **Low Boy Height:** Easy to apply in low ceiling applications, works well with taller high SEER coils, easier to handle and install.
- **Tubular primary heat exchanger:** Heavy gauge aluminized steel heat exchanger and stainless steel secondary heat exchanger assures a long life.
- **60 second fixed cooling cycle blower-off delay (TDR):** Increases cooling performance when matched with a Nortek Global HVAC coil.
- **LP convertible:** Simple burner orifice and regulator spring change for ease of convertibility.
- **Diagnostic lights for easy troubleshooting without counting flashes:** Dedicated light for flame signal strength and 2 lights in combination to indicate all other fault codes with easy to recognize states without counting flashes.
- **Incorporates integrated control board:** With connections for electronic air cleaner and humidifier. Ergonomically located for ease of service.
- **Two piece door design:** Enhances furnace appearance and uses captured screws to prevent losing door screws.
- **Sealed vestibule:** Reduces burner and inducer sound levels.
- **Furnace Air Leakage:** These furnaces comply with Energy Star cabinet air leakage requirement of less than or equal to 2%. Keep the conditioned air flowing to where it's needed.
- **PolyPro by DuraVent:** These furnaces have been tested with and are approved to be installed with DuraVent's PolyPro venting system.

LOCATION OF FURNACE COMPONENTS

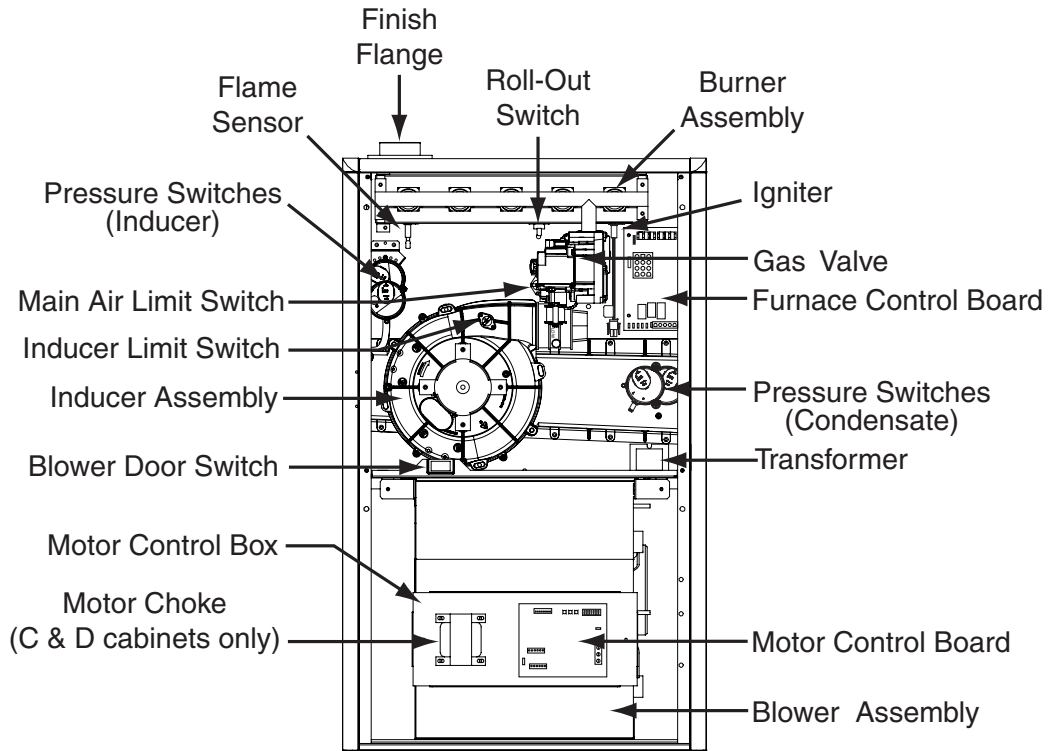

Upflow/Horizontal Gas Furnace Components

DIMENSIONS

*TC 95.1% Upflow/Horizontal Furnace

Cabinet Size	Dim. "A"	Dim. "B"	Dim. "C"
'B' Cabinet	17 1/2	15 7/8	16 1/8
'C' Cabinet	21	19 3/8	19 5/8
'D' Cabinet	24 1/2	22 7/8	23 1/8

NOTES:
Dimensions shown in inches.

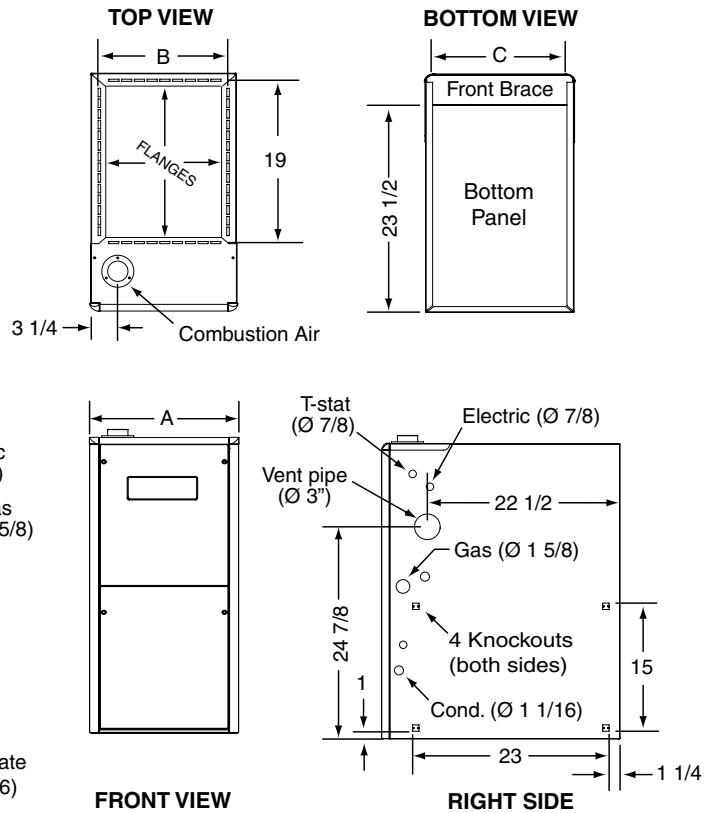

MODEL IDENTIFICATION CODE

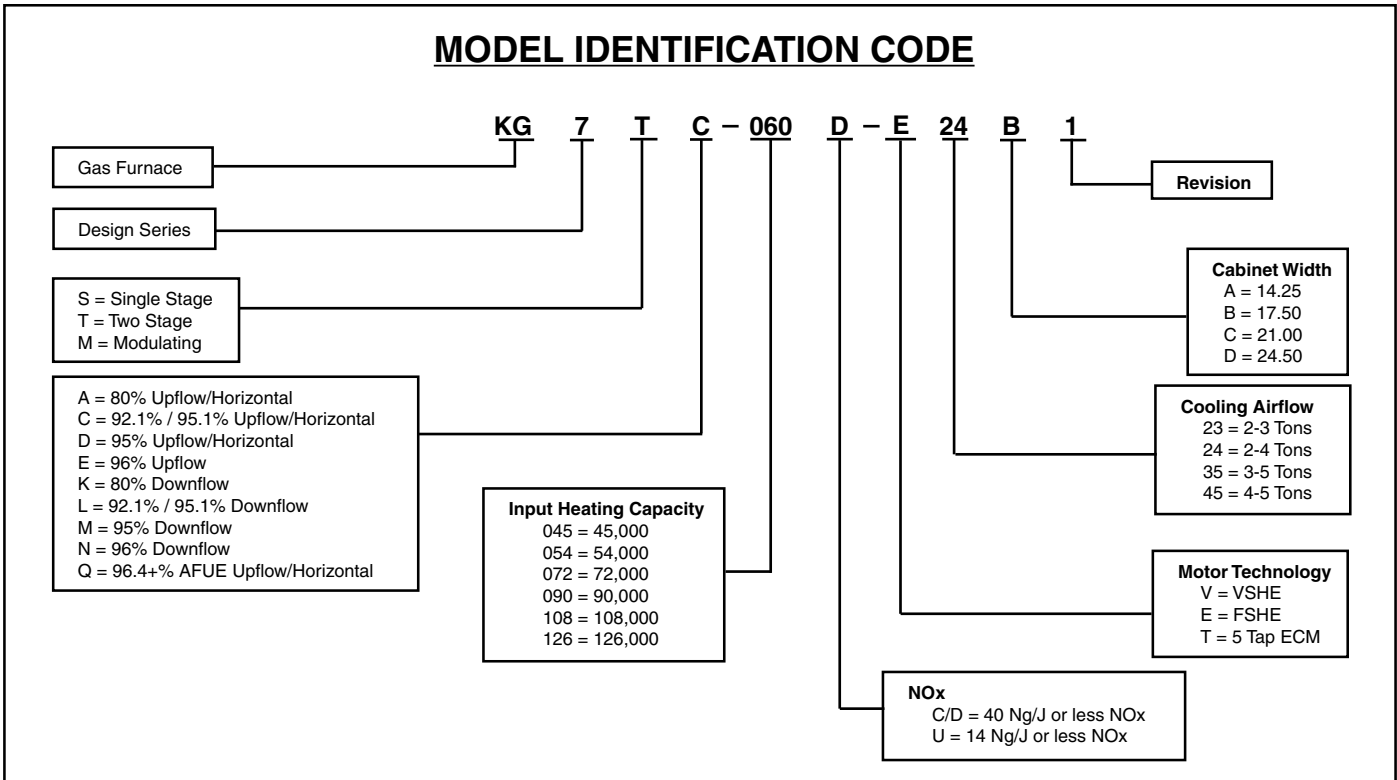

SPECIFICATIONS

KG7TC MODEL NUMBERS:	-060D-E24B1	-080D-E35C1	-100D-E35C1	-120D-E45D1
Input - Btuh (a)	60000 / 39000	80000 / 52000	100000 / 65000	120000 / 78000
Heating Capacity - BtuH	57000 / 37000	76000 / 49000	95000 / 62000	113000 / 74000
AFUE	95.0	95.0	95.0	94.3
Motor H.P. - Speed - Type	3/4 - BLDC	1 - BLDC	1 - BLDC	1 - BLDC
Motor FLA	8.8	11.5	11.5	11.5
Rated Ext. SP - In. W.C.	0.50	0.50	0.50	0.50
Temperature Rise Range - F	30-60	35-65	35-65	40-70
Shipping Weights	120 lb	130 lb	140 lb	155 lb
SKU	1025920K	1025921K	1025922K	1025923K

Note:

All models are 115V, 60 Hz. Gas Connections are 1/2" N.P.T. AFUE = Annual Fuel Utilization Efficiency
 (a) Ratings to 2,000 ft. Over 2,000 ft. reduce 4% for each 1,000 ft. above sea level.

KG7TC-060D-E24B (FSHE)

HEATING AIRFLOW (CFM) & TEMPERATURE RISE (°F)														
MODEL NUMBER/ HEATING INPUT	MOTOR SWITCH SETTINGS (0=OFF, 1=ON)				EXTERNAL STATIC PRESSURE (in. w.c.)									
					0.1		0.2		0.3		0.4		0.5	
	1	2	3	4	CFM	RISE	CFM	RISE	CFM	RISE	CFM	RISE	CFM	RISE
KG7TC-060D-E24B 60,000 BTU/hr	0	0	0	0										
	1	0	0	0										
	0	1	0	0										
	1	1	0	0										
	0	0	1	0										
	1	0	1	0	940	56	890	59						
	0	1	1	0	990	53	945	56	905	58				
	1	1	1	0	1,055	50	1,015	52	970	54	930	57	890	59
	0	0	0	1	1,135	47	1,095	48	1,055	50	1,010	52	960	55
	1	0	0	1	1,185	45	1,145	46	1,105	48	1,065	50	1,030	51
	0	1	0	1	1,250	42	1,210	44	1,170	45	1,135	47	1,095	48
	1	1	0	1	1,290	41	1,255	42	1,220	43	1,180	45	1,145	46
	0	0	1	1	1,315	40	1,275	41	1,240	43	1,200	44	1,160	45
	1	0	1	1	1,350	39	1,315	40	1,280	41	1,245	42	1,205	44
	0	1	1	1	1,390	38	1,350	39	1,315	40	1,275	41	1,240	43
1	1	1	1											

COOLING AIRFLOW (CFM)													
MODEL NUMBER/ HEATING INPUT	MOTOR SWITCH SETTINGS (0=OFF, 1=ON)				EXTERNAL STATIC PRESSURE (in. w.c.)								
					0.1	0.2	0.3	0.4	0.5	0.6	0.7	0.8	
	5	6	7	8	(CFM)	(CFM)	(CFM)	(CFM)	(CFM)	(CFM)	(CFM)	(CFM)	(CFM)
KG7TC-060D-E24B 60,000 BTU/hr	0	0	0	0									
	1	0	0	0									
	0	1	0	0									
	1	1	0	0	725								
	0	0	1	0	810								
	1	0	1	0	940	890	845	795	750	700			
	0	1	1	0	990	945	905	860	820	775	735	690	
	1	1	1	0	1,055	1,015	970	930	890	845	805	760	
	0	0	0	1	1,135	1,095	1,055	1,010	960	930	890	850	
	1	0	0	1	1,185	1,145	1,105	1,065	1,030	990	950	910	
	0	1	0	1	1,250	1,210	1,170	1,135	1,095	1,055	1,020	980	
	1	1	0	1	1,290	1,255	1,220	1,180	1,145	1,110	1,075	1,040	
	0	0	1	1	1,315	1,275	1,240	1,200	1,160	1,120	1,085	1,045	
	1	0	1	1	1,350	1,315	1,280	1,245	1,205	1,170	1,135	1,100	
	0	1	1	1	1,390	1,350	1,315	1,275	1,240	1,200	1,160	1,125	
1	1	1	1	1,420	1,380	1,345	1,310	1,270	1,235	1,200	1,160		

***NOTES:**

1. Motor switch settings for heating speeds use HEAT switches 1, 2, 3, & 4 and for cooling speeds use COOL switches 5, 6, 7, & 8.
2. To comply with government mandated efficiency standards, two openings are required for airflows above 1,600 CFM.
3. Data is shown without filter.
4. Temperature rises in the table are approximate. Actual temperature rises may vary.
5. Individual cells shaded in gray indicate a temperature rise outside of the recommended range.
6. To comply with government mandated efficiency standards, speed settings shaded in gray are not allowed in HEAT mode.
7. When in low stage heat, the airflow is approximately 70% of the tables high value (2-stage furnaces only).

KG7TC-080D-E35C (FSHE)

HEATING AIRFLOW (CFM) & TEMPERATURE RISE (°F)														
MODEL NUMBER/ HEATING INPUT	MOTOR SWITCH SETTINGS (0=OFF, 1=ON)				EXTERNAL STATIC PRESSURE (in. w.c.)									
					0.1		0.2		0.3		0.4		0.5	
	1	2	3	4	CFM	RISE	CFM	RISE	CFM	RISE	CFM	RISE	CFM	RISE
KG7TC-080D-E35C 80,000 BTU/hr	0	0	0	0	1,125	55								
	1	0	0	0	1,205	58	1,120	63						
	0	1	0	0	1,305	54	1,225	57	1,150	61				
	1	1	0	0	1,430	49	1,350	52	1,270	55	1,190	59	1,110	63
	0	0	1	0	1,525	46	1,450	49	1,375	51	1,300	54	1,225	57
	1	0	1	0	1,620	43	1,540	46	1,465	48	1,390	51	1,315	54
	0	1	1	0	1,695	42	1,620	43	1,545	46	1,465	48	1,390	51
	1	1	1	0	1,770	40	1,700	41	1,630	43	1,555	45	1,485	47
	0	0	0	1	1,875	38	1,805	39	1,730	41	1,655	43	1,580	45
	1	0	0	1	1,905	37	1,840	38	1,775	40	1,710	41	1,640	43
	0	1	0	1	1,980	36	1,910	37	1,845	38	1,780	40	1,715	41
	1	1	0	1	2,025	35	1,960	36	1,895	37	1,830	38	1,765	40
	0	0	1	1			2,025	35	1,960	36	1,900	37	1,840	38
	1	0	1	1					2,010	35	1,945	36	1,880	37
	0	1	1	1							2,035	35	1,980	36
	1	1	1	1										

COOLING AIRFLOW (CFM)												
MODEL NUMBER/ HEATING INPUT	MOTOR SWITCH SETTINGS (0=OFF, 1=ON)				EXTERNAL STATIC PRESSURE (in. w.c.)							
					0.1	0.2	0.3	0.4	0.5	0.6	0.7	0.8
	5	6	7	8	(CFM)	(CFM)	(CFM)	(CFM)	(CFM)	(CFM)	(CFM)	(CFM)
KG7TC-080D-E35C 80,000 BTU/hr	0	0	0	0	1,125	1,040	960	880	795			
	1	0	0	0	1,205	1,120	1,040	960	875	795		
	0	1	0	0	1,305	1,225	1,150	1,070	995	915	840	
	1	1	0	0	1,430	1,350	1,270	1,190	1,110	1,030	950	865
	0	0	1	0	1,525	1,450	1,375	1,300	1,225	1,150	1,075	1,000
	1	0	1	0	1,620	1,540	1,465	1,390	1,315	1,240	1,165	1,090
	0	1	1	0	1,695	1,620	1,545	1,465	1,390	1,315	1,235	1,160
	1	1	1	0	1,770	1,700	1,630	1,555	1,485	1,410	1,340	1,265
	0	0	0	1	1,875	1,805	1,730	1,655	1,580	1,510	1,435	1,340
	1	0	0	1	1,905	1,840	1,775	1,710	1,640	1,575	1,510	1,445
	0	1	0	1	1,980	1,910	1,845	1,780	1,715	1,650	1,580	1,515
	1	1	0	1	2,025	1,960	1,895	1,830	1,765	1,700	1,635	1,570
	0	0	1	1	2,085	2,025	1,960	1,900	1,840	1,775	1,715	1,655
	1	0	1	1	2,135	2,070	2,010	1,945	1,880	1,815	1,750	1,685
	0	1	1	1	2,200	2,145	2,090	2,035	1,980	1,925	1,870	1,820
	1	1	1	1	2,280	2,225	2,170	2,115	2,065	2,010	1,955	1,900

NOTES:

1. Motor switch settings for heating speeds use HEAT switches 1, 2, 3, & 4 and for cooling speeds use COOL switches 5, 6, 7, & 8.
2. To comply with government mandated efficiency standards, two openings are required for airflows above 1,600 CFM.
3. Data is shown without filter.
4. Temperature rises in the table are approximate. Actual temperature rises may vary.
5. Individual cells shaded in gray indicate a temperature rise outside of the recommended range.
6. To comply with government mandated efficiency standards, speed settings shaded in gray are not allowed in HEAT mode.
7. When in low stage heat, the airflow is approximately 70% of the tables high value (2-stage furnaces only).

KG7TC-100D-E35C (FSHE)

HEATING AIRFLOW (CFM) & TEMPERATURE RISE (°F)														
MODEL NUMBER/ HEATING INPUT	MOTOR SWITCH SETTINGS (0=OFF, 1=ON)				EXTERNAL STATIC PRESSURE (in. w.c.)									
					0.1		0.2		0.3		0.4		0.5	
	1	2	3	4	CFM	RISE	CFM	RISE	CFM	RISE	CFM	RISE	CFM	RISE
KG7TC-100D-E35C 100,000 BTU/hr	0	0	0	0										
	1	0	0	0										
	0	1	0	0										
	1	1	0	0	1,430	62	1,350	65						
	0	0	1	0	1,525	58	1,450	61	1,375	64				
	1	0	1	0	1,620	54	1,540	57	1,465	60	1,390	63		
	0	1	1	0	1,695	52	1,620	54	1,545	57	1,465	60	1,390	63
	1	1	1	0	1,770	50	1,700	52	1,630	54	1,555	57	1,485	59
	0	0	0	1	1,875	47	1,805	49	1,730	51	1,655	53	1,580	56
	1	0	0	1	1,905	46	1,840	48	1,775	50	1,710	51	1,640	54
	0	1	0	1	1,980	44	1,910	46	1,845	48	1,780	49	1,715	51
	1	1	0	1	2,025	43	1,960	45	1,895	46	1,830	48	1,765	50
	0	0	1	1	2,085	42	2,025	43	1,960	45	1,900	46	1,840	48
	1	0	1	1	2,135	41	2,070	42	2,010	44	1,945	45	1,880	47
	0	1	1	1	2,200	40	2,145	41	2,090	42	2,035	43	1,980	44
1	1	1	1											

COOLING AIRFLOW (CFM)														
MODEL NAME/ HEATING INPUT	MOTOR SWITCH SETTINGS (0=OFF, 1=ON)				EXTERNAL STATIC PRESSURE (in. w.c.)									
					0.1	0.2	0.3	0.4	0.5	0.6	0.7	0.8		
	5	6	7	8	(CFM)	(CFM)	(CFM)	(CFM)	(CFM)	(CFM)	(CFM)	(CFM)	(CFM)	
KG7TC-100D-E35C 100,000 BTU/hr	0	0	0	0	1,125	1,040								
	1	0	0	0	1,205	1,120	1,040							
	0	1	0	0	1,305	1,225	1,150	1,070	995					
	1	1	0	0	1,430	1,350	1,270	1,190	1,110	1,030				
	0	0	1	0	1,525	1,450	1,375	1,300	1,225	1,150	1,075	1,000		
	1	0	1	0	1,620	1,540	1,465	1,390	1,315	1,240	1,165	1,090		
	0	1	1	0	1,695	1,620	1,545	1,465	1,390	1,315	1,235	1,160		
	1	1	1	0	1,770	1,700	1,630	1,555	1,485	1,410	1,340	1,265		
	0	0	0	1	1,875	1,805	1,730	1,655	1,580	1,510	1,435	1,340		
	1	0	0	1	1,905	1,840	1,775	1,710	1,640	1,575	1,510	1,445		
	0	1	0	1	1,980	1,910	1,845	1,780	1,715	1,650	1,580	1,515		
	1	1	0	1	2,025	1,960	1,895	1,830	1,765	1,700	1,635	1,570		
	0	0	1	1	2,085	2,025	1,960	1,900	1,840	1,775	1,715	1,655		
	1	0	1	1	2,135	2,070	2,010	1,945	1,880	1,815	1,750	1,685		
	0	1	1	1	2,200	2,145	2,090	2,035	1,980	1,925	1,870	1,820		
1	1	1	1	2,280	2,225	2,170	2,115	2,065	2,010	1,955	1,900			

NOTES:

1. Motor switch settings for heating speeds use HEAT switches 1, 2, 3, & 4 and for cooling speeds use COOL switches 5, 6, 7, & 8.
2. To comply with government mandated efficiency standards, two openings are required for airflows above 1,600 CFM.
3. Data is shown without filter.
4. Temperature rises in the table are approximate. Actual temperature rises may vary.
5. Individual cells shaded in gray indicate a temperature rise outside of the recommended range.
6. To comply with government mandated efficiency standards, speed settings shaded in gray are not allowed in HEAT mode.
7. When in low stage heat, the airflow is approximately 70% of the tables high value (2-stage furnaces only).

KG7TC-120D-E45D (FSHE)

HEATING AIRFLOW (CFM) & TEMPERATURE RISE (°F)															
MODEL NUMBER/ HEATING INPUT	MOTOR SWITCH SETTINGS (0=OFF, 1=ON)				EXTERNAL STATIC PRESSURE (in. w.c.)										
					0.1		0.2		0.3		0.4		0.5		
	1	2	3	4	CFM	RISE	CFM	RISE	CFM	RISE	CFM	RISE	CFM	RISE	
KG7TC-120D-E45D 120,000 BTU/hr	0	0	0	0											
	1	0	0	0											
	0	1	0	0	1,555	68	1,510	70							
	1	1	0	0	1,625	65	1,585	67	1,540	69	1,500	70			
	0	0	1	0	1,690	62	1,650	64	1,610	66	1,570	67	1,530	69	
	1	0	1	0	1,760	60	1,715	62	1,670	63	1,625	65	1,575	67	
	0	1	1	0	1,835	58	1,790	59	1,745	60	1,695	62	1,650	64	
	1	1	1	0	1,885	56	1,840	57	1,790	59	1,745	60	1,700	62	
	0	0	0	1	1,945	54	1,900	56	1,850	57	1,805	58	1,760	60	
	1	0	0	1	1,950	54	1,905	55	1,860	57	1,820	58	1,775	59	
	0	1	0	1	2,075	51	2,030	52	1,990	53	1,945	54	1,900	56	
	1	1	0	1	2,125	50	2,085	51	2,040	52	2,000	53	1,955	54	
	0	0	1	1	2,170	49	2,130	50	2,090	51	2,045	52	2,005	53	
	1	0	1	1	2,215	48	2,180	48	2,140	49	2,105	50	2,070	51	
	0	1	1	1										2,225	47
	1	1	1	1											

COOLING AIRFLOW (CFM)													
MODEL NAME/ HEATING INPUT	MOTOR SWITCH SETTINGS (0=OFF, 1=ON)				EXTERNAL STATIC PRESSURE (in. w.c.)								
					0.1	0.2	0.3	0.4	0.5	0.6	0.7	0.8	
	5	6	7	8	(CFM)	(CFM)	(CFM)	(CFM)	(CFM)	(CFM)	(CFM)	(CFM)	
KG7TC-120D-E45D 120,000 BTU/hr	0	0	0	0	1,395	1,350	1,305	1,260	1,210	1,165	1,120		
	1	0	0	0	1,465	1,420	1,375	1,330	1,290	1,245	1,200	1,155	
	0	1	0	0	1,555	1,510	1,470	1,425	1,380	1,340	1,295	1,250	
	1	1	0	0	1,625	1,585	1,540	1,500	1,460	1,415	1,375	1,335	
	0	0	1	0	1,690	1,650	1,610	1,570	1,530	1,485	1,445	1,405	
	1	0	1	0	1,760	1,715	1,670	1,625	1,575	1,530	1,485	1,440	
	0	1	1	0	1,835	1,790	1,745	1,695	1,650	1,605	1,555	1,510	
	1	1	1	0	1,885	1,840	1,790	1,745	1,700	1,655	1,610	1,565	
	0	0	0	1	1,945	1,900	1,850	1,805	1,760	1,710	1,665	1,620	
	1	0	0	1	1,950	1,905	1,860	1,820	1,775	1,735	1,690	1,650	
	0	1	0	1	2,075	2,030	1,990	1,945	1,900	1,855	1,810	1,770	
	1	1	0	1	2,125	2,085	2,040	2,000	1,955	1,910	1,870	1,825	
	0	0	1	1	2,170	2,130	2,090	2,045	2,005	1,965	1,925	1,880	
	1	0	1	1	2,215	2,180	2,140	2,105	2,070	2,035	2,000	1,965	
	0	1	1	1						2,225	2,165	21,000	2,040
	1	1	1	1						2,170	2,120	2,065	

NOTES:

1. Motor switch settings for heating speeds use HEAT switches 1, 2, 3, & 4 and for cooling speeds use COOL switches 5, 6, 7, & 8.
2. To comply with government mandated efficiency standards, two openings are required for airflows above 1,600 CFM.
3. Data is shown without filter.
4. Temperature rises in the table are approximate. Actual temperature rises may vary.
5. Individual cells shaded in gray indicate a temperature rise outside of the recommended range.
6. To comply with government mandated efficiency standards, speed settings shaded in gray are not allowed in HEAT mode.
7. When in low stage heat, the airflow is approximately 70% of the tables high value (2-stage furnaces only).

VENTING

All models are approved for vertical non direct (1 pipe) and direct (2 pipe) venting applications. See Vent Table below for specified sizes and allowable lengths.

VENT TABLE

FURNACE MODELS (BTU)	FURNACE INSTALLATION	SINGLE PIPE LENGTH (FT.) with 1 long radius elbow**		DIRECT VENT, DUAL PIPE LENGTH (ft.) WITH 1 long radius elbow on each pipe**	
		OUTLET	OUTLET	INLET/OUTLET	INLET/OUTLET
		2" Diameter	3" Diameter	2" Diameter	3" Diameter
60,000	Upflow	90	90	90	90
	Horizontal	50	90	50	90
80,000	Upflow	40	90	40	90
	Horizontal	30	90	30	90
100,000	Upflow	30	90	30	90
	Horizontal	30	90	30	90
120,000	Upflow	N/A	90	N/A	90
	Horizontal	N/A	90	N/A	90

***NOTES:**

1. Subtract 2.5 ft. for each additional 2 inch long radius elbow, 5 ft. for each additional 2 inch short radius elbow, 3.5 ft. for each additional 3 inch long radius elbow, and 7 ft. for each additional 3 inch short radius elbow. Subtract 5ft for each 2" tee and 8ft for each 3" tee.
2. Two 45 degree elbows are equivalent to one 90 degree elbow.
3. This table applies for elevations from sea level to 2,000 ft. For higher elevations, decrease pipe lengths by 8% per 1,000 ft of altitude.

ACCESSORIES

KG7TC KITS	
Description	SKU
2" Concentric Vent Kit, US approved only	904177
3" Concentric Vent Kit, US approved only	904176
2" Concentric Vent Kit, Canadian and US approved	904952
3" Concentric Vent Kit, Canadian and US approved	904953
2" Side Wall Vent Kit	904617
3" Side Wall Vent Kit	904347
U.S. LP Conversion Kit (0 to 10,000 ft.)	905028
Canada LP Conversion Kit (0 to 4,500 ft.)	905029
Bottom Return Filter 20 per Box, "B" Cabinet	904916
Bottom Return Filter 20 per Box, "D" Cabinet	904918
Side Return Filter Kit	541036
Neutralizer Kit	902377
Furnace Twinning Kit	1010035



GENERAL TERMS OF LIMITED WARRANTY

Nortek Global HVAC, LLC will furnish a replacement for any part of this product which fails in normal use and service within the terms and conditions of the warranty.

For complete details of the Limited Warranty, including applicable terms and conditions, see your local installer or contact the Nortek Global HVAC, LLC warranty department for a copy.

Before purchasing this appliance, read important energy cost and efficiency information available from your retailer. Specifications and illustrations subject to change without notice and without incurring obligations. Printed in U.S.A (06/2019)